

TOYO TIRE TALK



Report No.	06 - 009
TTT No.	TTT - 189
Report Date	Nov. 24, 2006

Issued by Technical Service Department of TOYO Japan.

Subject : Tire Test Method

The endurance and strength of a tire is very important for vehicle safety. To ensure this, tyres must attain a minimum standard. Most countries adopt or refer to the regulations and test methods established by the Economic Commission for Europe (ECE) or by the Department Of Transportation in the USA (FMVSS). The test methods of the two major tire regulations are explained in this TTT.

The following table summarizes the regulations application and the tests conducted.

- ▶ ECE has an endurance test and a dimension test.
- ▶ FMVSS has an endurance test, tire strength test, and bead unseating test.

(Note : the dimension test is not covered in this TTT)

Region	Regulation	Target Vehicle	High Speed Performance	Tire Endurance	Low Inflation Pressure Performance	Tire Strength	Bead Unseating Resistance	Tire Dimension
Europe	ECE-R30	Passenger Car	○					○
	ECE-R54	Commercial Veh.	○	○				○
U.S.A.	FMVSS109	Passenger Car	○	○		○	○	○
	FMVSS119	Commercial Veh.		○		○		
	FMVSS139*	Veh. ≤ 10,000lbs	○	○	○	○	○	○

* FMVSS139 is a new standard which has been introduced due to the tire recall by Firestone and Ford. This standard applies from September 2007 to tires for use on vehicles that have a gross vehicle weight rating of 10,000lbs (4,536 kg) or less.

The test method used to evaluate each tire performance requirement, and the different requirements of ECE Vs. FMVSS and FMVSS109 Vs. FMVSS139 are explained below.

Test Method.

1) High Speed Performance, Tire Endurance and Low Inflation Pressure Performance tests are evaluated by a test drum (Figure 1). The test tire is pressed against the surface of the rotating drum at the required load and speed. If the tire does not fail after running, it passes the test.

Test Items	Test Speed	Test Load
High Speed Performance	Step Up	Constant
Tire Endurance	Constant	Step Up
Low Inflation Pressure Performance	Constant	Constant

The diameter of the drum is fixed by the standard.

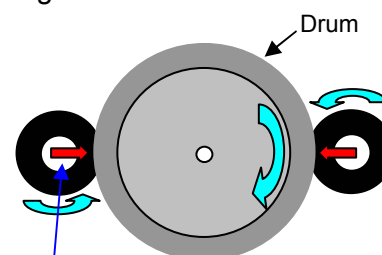

The test tire is loaded against the drum surface.

Figure 1

2) Tire Strength is evaluated by applying a force in the tread area of the tire. The breaking energy is calculated by the amount of force required, and the depth of penetration. It is measured by pressing the tire onto a cylindrical steel plunger (Figure 2). The dimension of the cylindrical steel plunger is fixed by the standard.

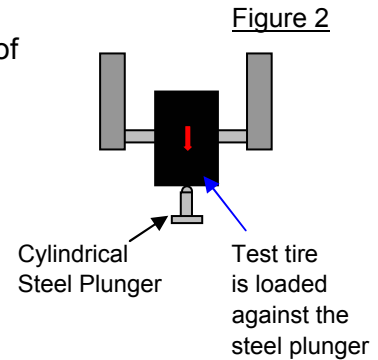
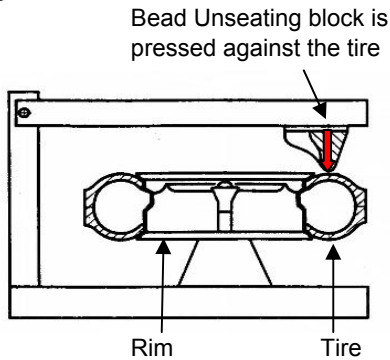

Figure 3



3) Bead Unseating Resistance for a tubeless tire is measured by how much force is required to separate the bead from the rim flange. The force is measured by pressing the bead unseating block against the tire bead area (Figure 3). The dimension of the bead unseating block is a standard size.

Comparison with Test Requirements

ECE-R30 Vs. FMVSS109

215/45R17 87W Standard Max load 545kg / Max Speed 270km/h

	Load	Infl. Press	1	2	3	4	5
ECE-R30	371 kg	320 kPa	10 mins	10 mins	10 mins	10 mins	20 mins
	68%		0 - 230	230 km/h	240 km/h	250 km/h	260 km/h
FMVSS109	480 kg	220 kPa	120 min	Cool	30 mins	30 mins	30 mins
	88%		80 km/h	Down	121 km/h	129 km/h	137 km/h

* The test speed condition of UTQG is FMVSS109 plus step up.

The test speed for ECE-R30 is decided by speed symbol of the tire. That of FMVSS109 is fixed. However, the high speed endurance of tires for USA is evaluated by UTQG* condition.

ECE-R54 Vs. FMVSS119

315/80R22.5 154M Max load 3,750kg at 830kPa / Max speed 130km/h

	Speed	Infl. Press	1	2	3
ECE-R54	73 km/h	830 kPa	2,475 kg	3,150 kg	3,788 kg
	SS = M		66%	84%	101%
FMVSS119	49 km/h	830 kPa	2,475 kg	3,150 kg	3,788 kg
	16 P.R.		66%	88%	101%

Test load of ECE-R30 is the same as FMVSS119. The test speed of ECE-R54 is decided by the speed symbol. That of FMVSS119 is decided by the ply rating.

FMVSS109 Vs. FMVSS139

215/45R17 87W STD Max load 545kg / Max Speed 270km/h

High Speed Performance

	Load	Infl. Press	1	2	3	4	5
FMVSS109	480 kg	220 kPa	120 min	Cool	30 mins	30 mins	30 mins
	88%		80 km/h	Down	121 km/h	129 km/h	137 km/h
FMVSS139	464 kg	220 kPa	120 min	Cool	30 mins	30 mins	30 mins
	85%		80 km/h	Down	140 km/h	150 km/h	160 km/h

The test speed of FMVSS139 is higher than that of FMVSS109.

Tire Endurance

	Speed	Infl. Press	1	2	3
			4 hr	6 hr	24 hr
FMVSS109	80 km/h	180 kPa	464 kg	491 kg	545 kg
			85%	90%	100%
FMVSS139	120 km/h	180 kPa	464 kg	491 kg	545 kg
			85%	90%	100%

The test speed of FMVSS139 is higher than that of FMVSS109.

Low Inflation Pressure Performance

	Speed	Infl. Press	1	2	3	4	Infl. Press	5
			4 hr	6 hr	24 hr			2 hr
FMVSS139	120 km/h	180 kPa	464 kg	491 kg	545 kg	Cool Down	140 kPa	545 kg
			85%	90%	100%			100%

This part is the Endurance Test of FMVSS139.

This test is carried out on a tire which has completed the tire Endurance Test.

The basic criteria is that the test tires do not fail during or after the test.

"E" and "DOT" Marks

The "E" mark shows that the tire has passed the ECE-R standard, and the "DOT" mark shows that the tire has passed the FMVSS standard. All Toyo tires exceed the relevant regulation requirements.

However, it is impossible to prevent the deterioration of a tire's performance due to improper use and poor maintenance. It is very important that the tyres are used and maintained correctly.



E mark



DOT mark